



License # JB5431

Palm Beach (561) 746-7969
Martin County (772) 334-7007
St. Lucie (772) 337-2131
Indian River (772) 778-5507
1572 SE S. Niemeyer Circle, Port St. Lucie, FL 34952

Serving Since 1991



- Custom Integrated Rim Mounted Bracket
- Zero Cracked or Damaged Drum Lids
- Convenient No Hassle Installation
- Weather and Corrosion Resistant
- 3 function Extended Range Remote Control
- Tamper Proof - Lockable cabinet

BMS TANK MOUNTED SYSTEM
offers the most advanced controller in the industry today, coupled with the industries first custom rim mounted bracket to ensure zero cracked or collapsed drum lids. Available in both Digital and Analog.

BMS TANK MOUNT System - The ultimate in mosquito FREE living **without cracked lids!**

The BMS Tankmount has been designed and manufactured by Bug DeFence to ensure that we could deliver the industries advanced, convenient, most reliable custom rim mounted mosquito misting system all at an extremely affordable price.

The BMS Tankmount is available with either an analog or digital controller (as shown below). While both offer the same Bug DeFence quality, dependability and variable run times, the BMS digital provides advanced programming and diagnostics for enhanced functionality, precise application and reliability.

Features of the BMS Tank mount System

- Guaranteed no cracked or collapsed lids
 - Integrated Controller Design - pump and programmable controller in one clean polished system
 - Surge protection
 - Advanced Programming Capabilities - Event Timer, Repeat Cycle, Everyday, Individual Day, Weekday/Weekend *
 - Digital Display with Touch Pad Programming and Indicator Lights for Accessories - Rain, Wind, Tank Level, Auto Run, Alarm Pump, Tank Mixer *
 - Adaptive Microprocessor with Real Time Clock *
 - Internal Battery back up *
 - Password protection *
 - Data Collection Capabilities: Runtime, Pump Hours, Daily Peak Temperature, Daily Peak Current *
 - Board mounted RF (radio frequency) receiver - extended range
- * Available on digital controller only

BMS Digital System



BMS Analog System



Ideal For:

Patios
Tennis Courts
Greenhouses
Resorts/Hotels
Shopping Centers

Gazebos
Rockscapes
Barns
Loading Docks
Factories

Pool Areas
Landscapes
Restaurants
Nurseries
Warehouses

Standard Install Configuration

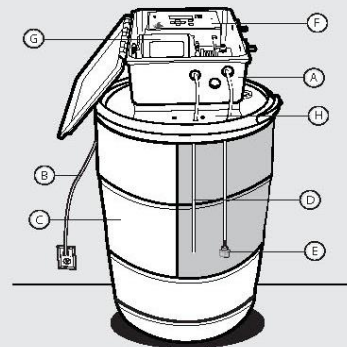

PART	DESCRIPTION
A	BMS Controller
B	Power Cord
C	55 Gallon Drum
D	Return Line
E	Strainer
F	Digital Timer
G	Pump
H	Custom Mounting Bracket

Compare Tank Mount Systems...



Competitor

Bug DeFence

Optional Accessories for the BMS:



3-function remote



Rain Sensor



Wind Sensor

